

GRAVITY OUTLET

Model 5097



SMBC RAIL SERVICES

The model 5097 gravity outlet gate is specifically designed for fast, efficient, controlled discharge of a wide variety of dry bulk materials. The model 5097 outlet meets or exceeds all requirements of AAR standard S-233-92.

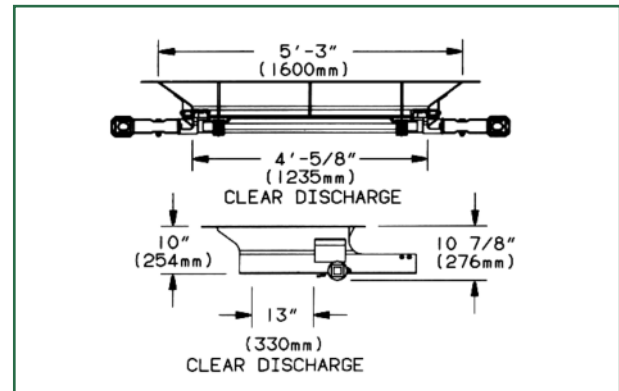

Design Features

The 5097 gravity outlet utilizes an automated locking device; long lasting, replaceable gate seals; reliable fixed capstan design; and allows the use of both manual and automated gate opening devices.

Sizes

The 5097 gravity outlet may be configured to fit a standard 32 bolt or 64 bolt Center Flow® mounting frame, and is designed to fit a 13" x 48" unloading boot or two (2) 13" x 24" unloading boots.

Regulatory Status

Meets or exceeds G.E.A.P.S./ A.A.R specifications S-233-92, for application of gravity outlet gates to new or rebuilt covered hopper cars.